



PV SYSTEMS

Building Integrated Photovoltaics

Building integrated PV

- Potential of urban solar
- BIPV issues
 - Inclination
 - Orientation
 - Shading
 - Temperature
 - Design
- PV & architecture
- Categories of BIPV
- PV integrated in public spaces

Potential of urban solar



Renewable and Sustainable Energy
Reviews

Volume 114, October 2019, 109309



A high-resolution geospatial assessment
of the rooftop solar photovoltaic
potential in the European Union

Katalin Bódis ^a, Ioannis Kougias ^{a, R. E.}, Arnulf Jäger-Waldau ^a, Nigel Taylor ^a, Sándor Szabó ^b

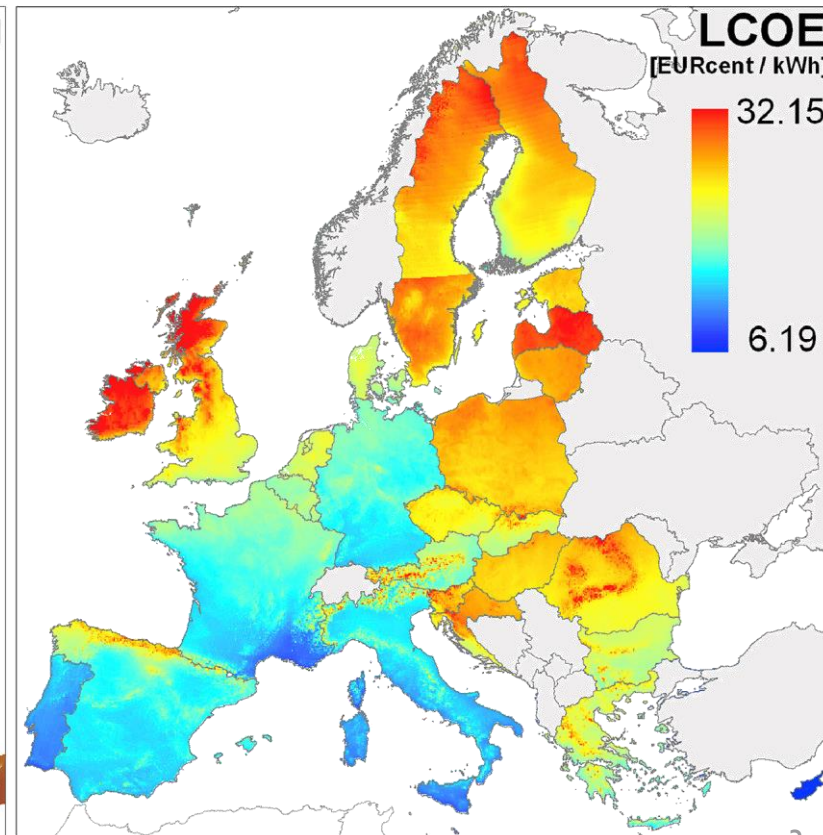
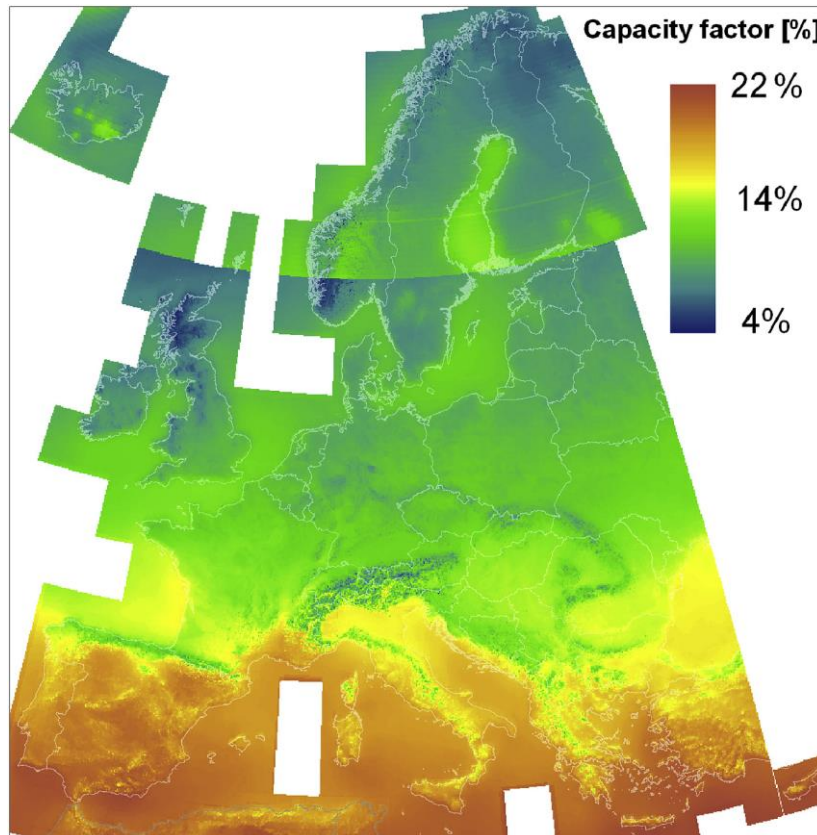

Potential of urban solar



Renewable and Sustainable Energy
Reviews

Volume 114, October 2019, 109309



A high-resolution geospatial assessment of the rooftop solar photovoltaic potential in the European Union

Katalin Bódis^a, Ioannis Kougias^{a, R. E.}, Arnulf Jäger-Waldau^a, Nigel Taylor^a, Sándor Szabó^b

In Portugal, rooftop PV is almost always cost competitive and could supply over 40% of national power consumption (2016 levels)

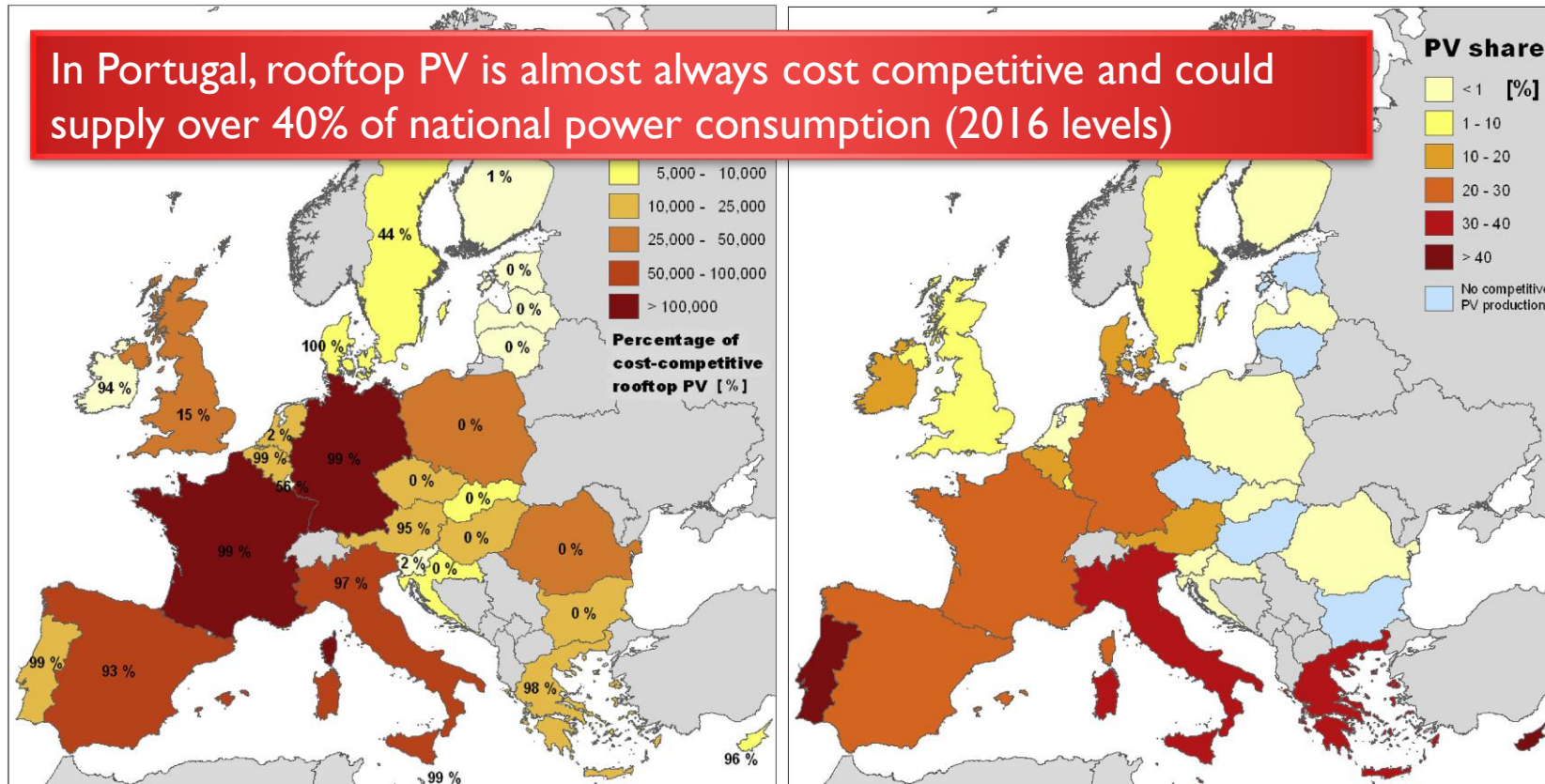

Building integrated PV

- Optimal **inclination** for maximizing energy yield but aesthetically it may not make sense
- Optimal **orientation** usually south (north) but not always (e.g. in a region prone to early morning fog, optimal may be slightly to the west)

Building integrated PV

- Importance of **shading** – crucial during system & building design (micro-inverters make PV system more tolerant to shading mistakes)

Building integrated PV

- Importance of shading – crucial during system & building design (micro-inverters make PV system more tolerant to shading mistakes)
- Notice that **high surrounding buildings** may also alter (i.e. usually block!) diffusive light

Building integrated PV



Building integrated PV



Building integrated PV



Building integrated PV

- Importance of **temperature**: (ventilated) air gap behind module to keep 'low' module temperature (extra: insulating function!)
- **Design!**
 - 'High-tech' or 'Green' look
 - Replacement for other facade materials (e.g. office building)

HOW CAN PV BE INCORPORATED INTO THE BUILDING DESIGN?

1. added technical element
2. added elements with double function
3. free standing structure
4. part of surface composition
5. complete façade/roof surface
6. form optimized for solar energy

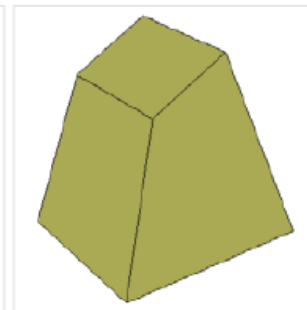
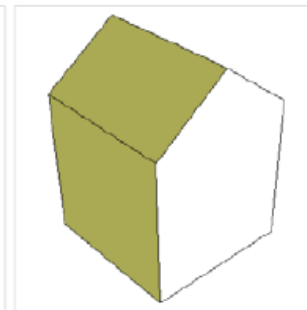
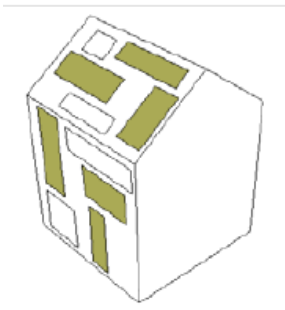
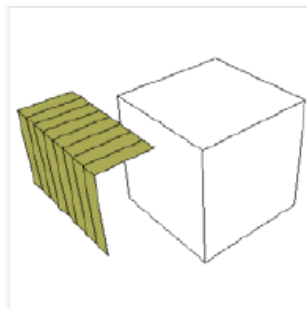
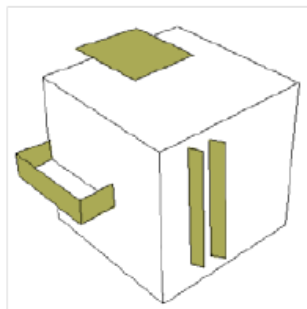
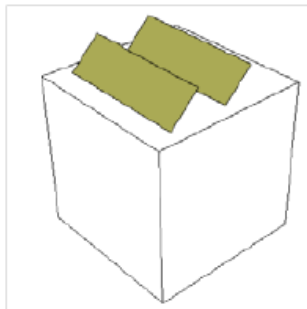

HOW CAN PV BE INCORPORATED INTO THE BUILDING DESIGN?

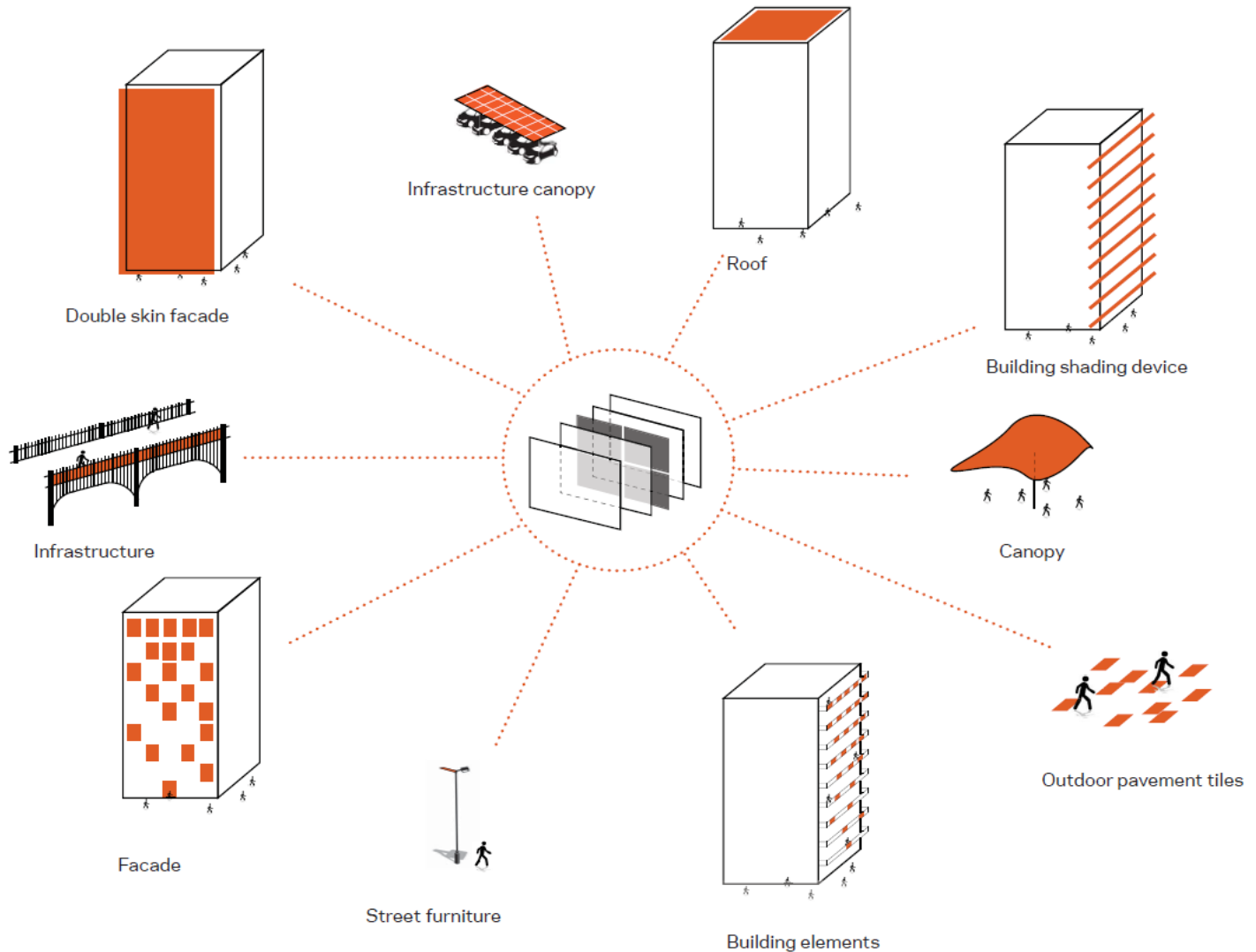

MANY DIFFERENT CLASSIFICATION SCHEMES

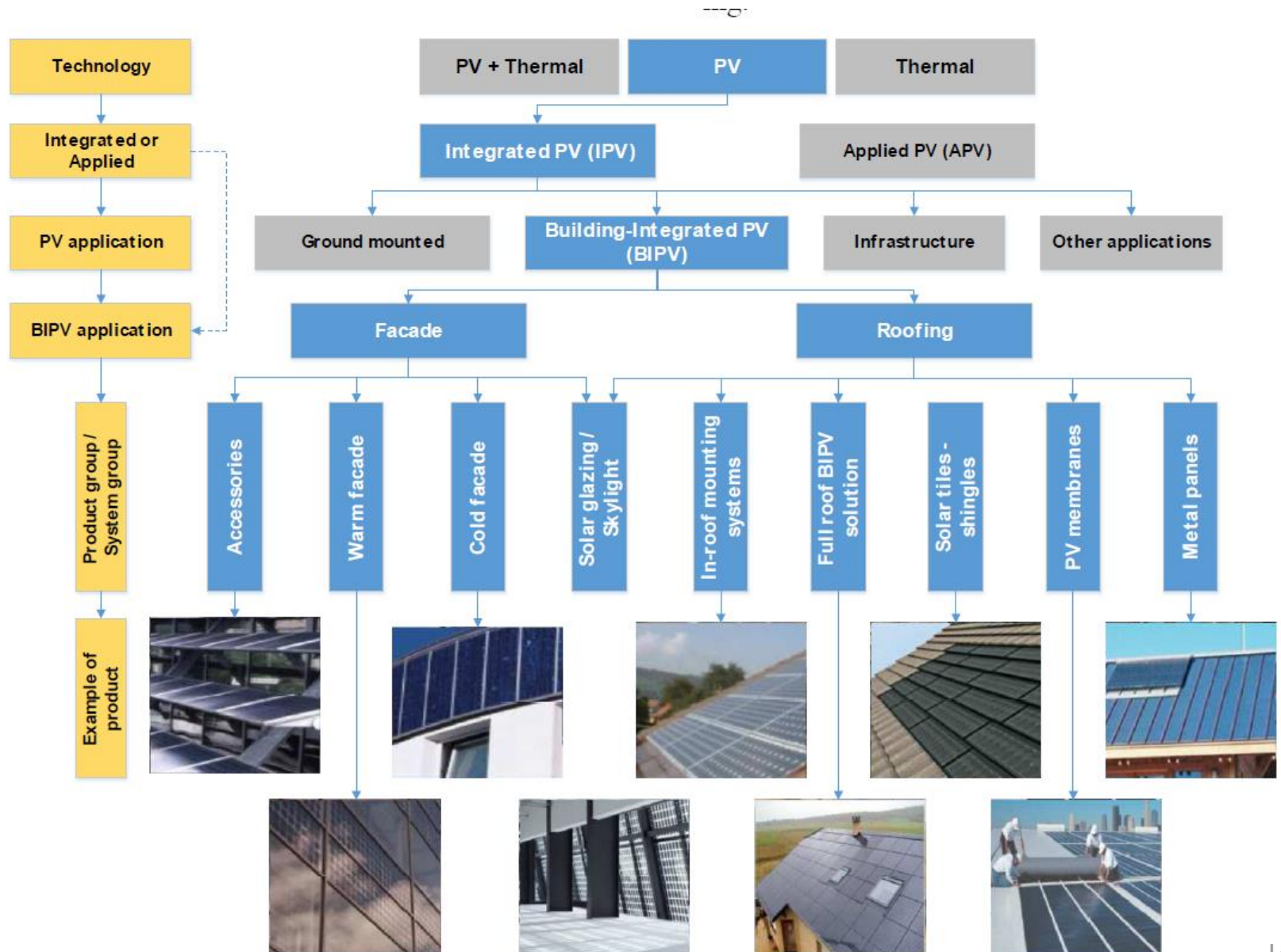

SOLAR ROOF TILES



LARGE SIZED TILES (SOURCES: WWW.NEWROOF-HYBRID.COM)



SMALL SIZED TILES (SOURCES: PANOTRON, FORNACE FONTI)



Solar tiles: Joint QREN project coordinated by Revigres, Innovation Award in "Energy Live Expo" 2012.

SOLAR ROOF TILES

SCX SOLOROOF AS BIPV FULL ROOF SOLUTION (TILBURG, THE NETHERLANDS), 75 TERRACED DWELLINGS



STAFIER STANDAARD AS AN IN-ROOF MOUNTING SYSTEM (MAARN, THE NETHERLANDS), 29 TERRACED DWELLINGS

SOLAR ROOFTILES



METAL PV PANELS (SOURCE: KALZIP, TEGOLA CANADESE)



PV MEMBRANES EMBEDDED IN A FLAT ROOF COVER (SOURCE: WEKA DAKSYSTEMEN).

SOLAR GLAZING

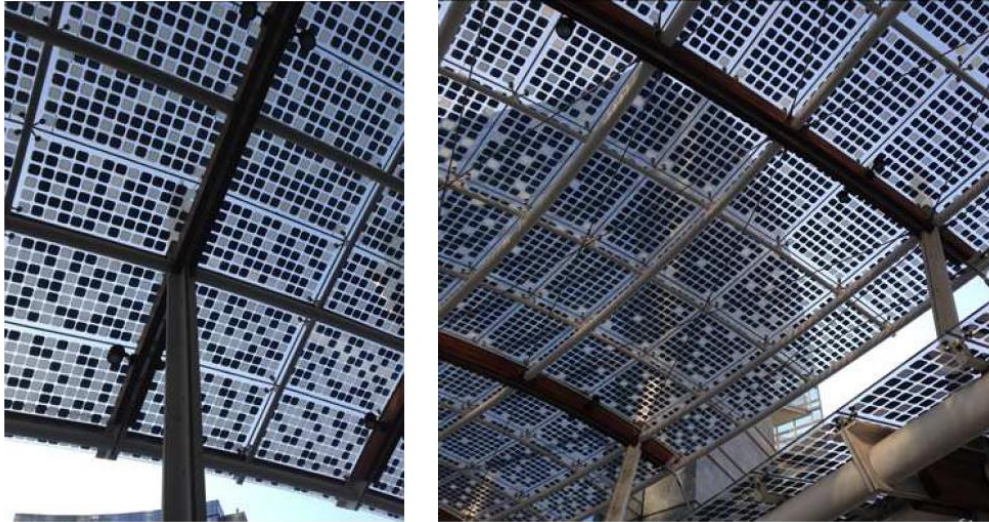

PORTA NUOVA MILANO - PIAZZA AULENTI (SOURCE: ENERGY GLASS)



THE "HERON TOWER" IN LONDON WITH THE SEMI-TRANSPARENT DOBLE SKIN -BIPV FAÇADE (PICTURE: P. BONOMO).

SOLAR FACADES



WARM FAÇADE BIPV SOLUTION, MONTE ROSA HUT (ZERMATT, SWITZERLAND) (ARCHITECT: ETH STUDIO MONTE ROSA)



Fig. 3.B.24: warm façade solution. Zara Fashion Store, Cologne, Germany, Architekturbüro Angela und Georg Feinhals: opaque monocrystalline cells combined with transparent glazing in post-beam curtain wall structure, © Solon.

SOLAR FACADES



WARM FAÇADE BIPV SOLUTION, PALAZZO POSITIVO (CHIASO, SWITZERLAND)

(ARCHITECT: TOUR BAUMANAGEMENT AG, BAD RAGAZ, PICTURES: F. FRONTINI, SUPSI)

SOLAR FACADES

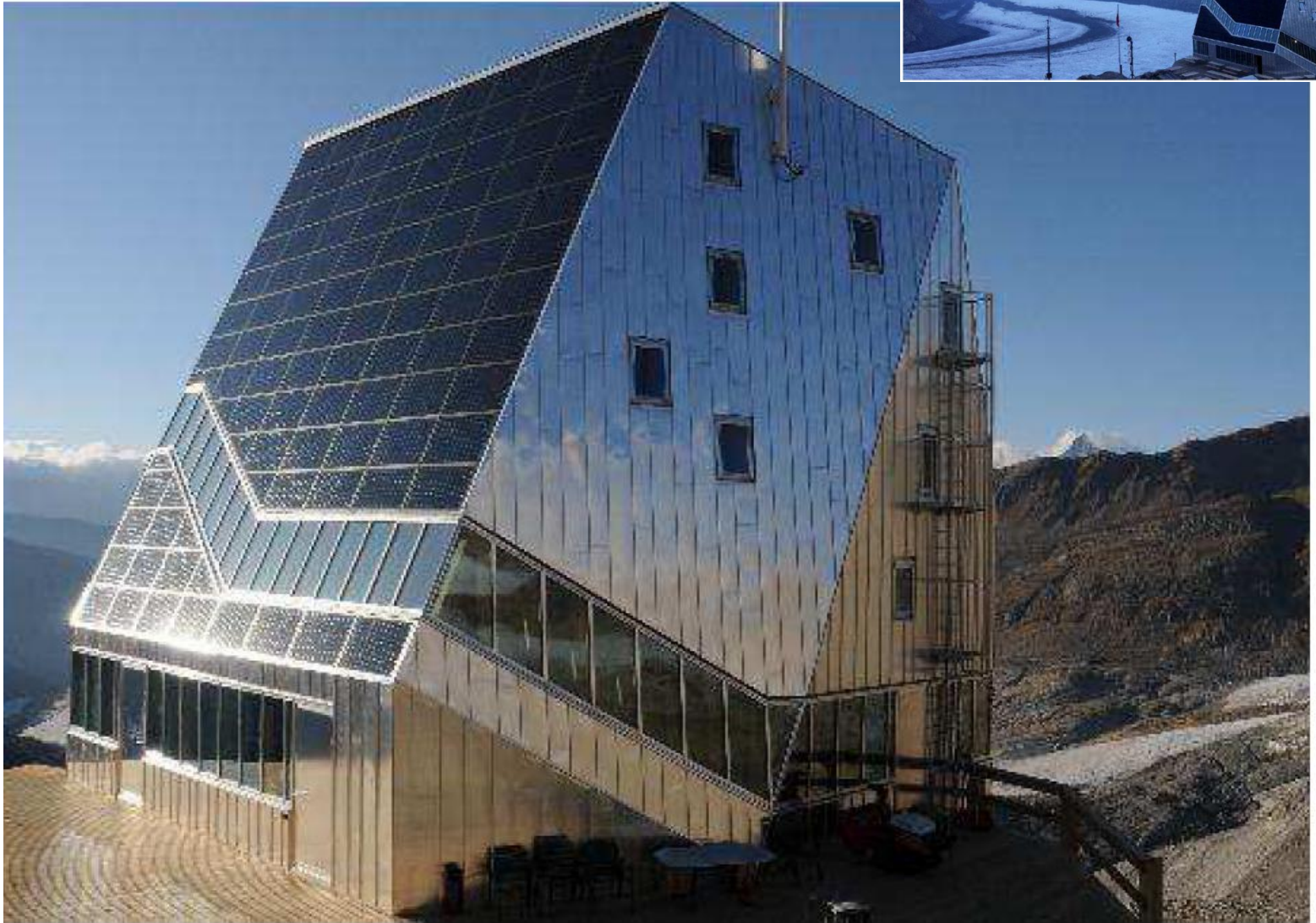

WARM FAÇADE BIPV SOLUTION, MONTE ROSA HUT (ZERMATT, SWITZERLAND) (ARCHITECT: *ETH STUDIO MONTE ROSA*)

SOLAR FACADES



Cold facades
have an air gap
for ventilation

PALAZZO POSITIVO IN CHIASSO (SWITZERLAND), REFURBISHMENT WITH A BIPV COLD FACADE (SOURCE: F. FRONTINI, SUPSI)



COLD FAÇADE BIPV SOLUTION, FRODEPARKEN (UPPSALA, SWEDEN) (ARCHITECT: *WHITE ARCHITECTS*)



SOLAR ACCESSORIES



Fig. 3.B.28: solar shading solution: Left: Colt Ellisse PV sliding shades at Company HQ, Bitterfeld-Wolfen, Germany, © Colt, Right: Keuringsdienst, Eindhoven, The Netherlands, Yanovshtchinsky Architekten: using Colt Shadovoltaic as shading device, © Colt.



Fig. 3.B.29 SBL Offices Linz, Austria, Helmut Schimek, shading louvres with integrated photovoltaics and suntracking system, © Colt

SOLAR ACCESSORIES



PV SHADINGS IN THE SIEEB BUILDING, BEIJING, MARIO CUCINELLA ARCHITECTS (SOURCE: WWW.SINOITAENVIRONMENT.ORG/)

SOLAR ACCESSORIES

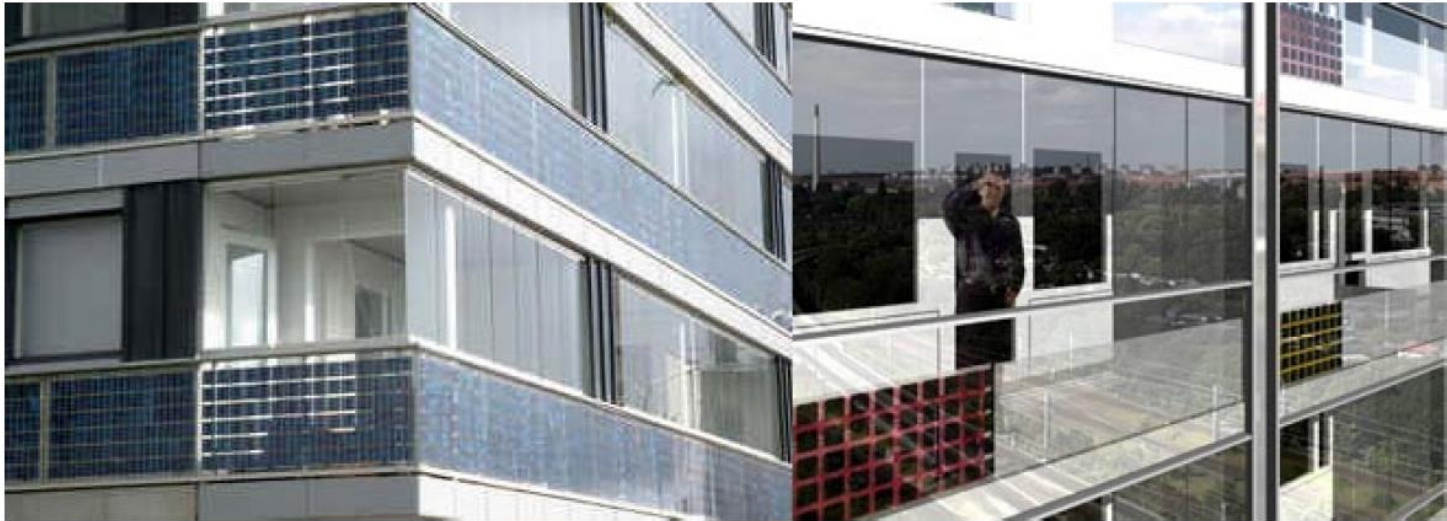

Fig. 3.B.30: spandrels and parapet solutions. Left: Housing Estate, Ekovikki, Finland, Oy Reijo Jallinoja: semi-transparent PV modules with two-paned glazing in parapet areas, Resource: PV NORD. Right: Kollektivhuset, Copenhagen, Denmark, Domus Arkitekter: PV cells were laminated to a single glass, heat transmitted from the cells was used in an innovative way to create thermal comfort during spring and autumn, during summer they are ventilated with an optimized shaft behind the cells and a coloured shutter through airgaps in the bottom and top of the glazing of the balcony, Resource: PV NORD.



SOLAR ACCESSORIES



TEXTILE PV ARCHITECTURE, SOFT HOUSE, IBA HAMBURG KENNEDY & VIOLICH ARCHITECTURE (SOURCE: WWW.IBA-HAMBURG.DE/)





ENERGY + HEALTH

Vauxhall

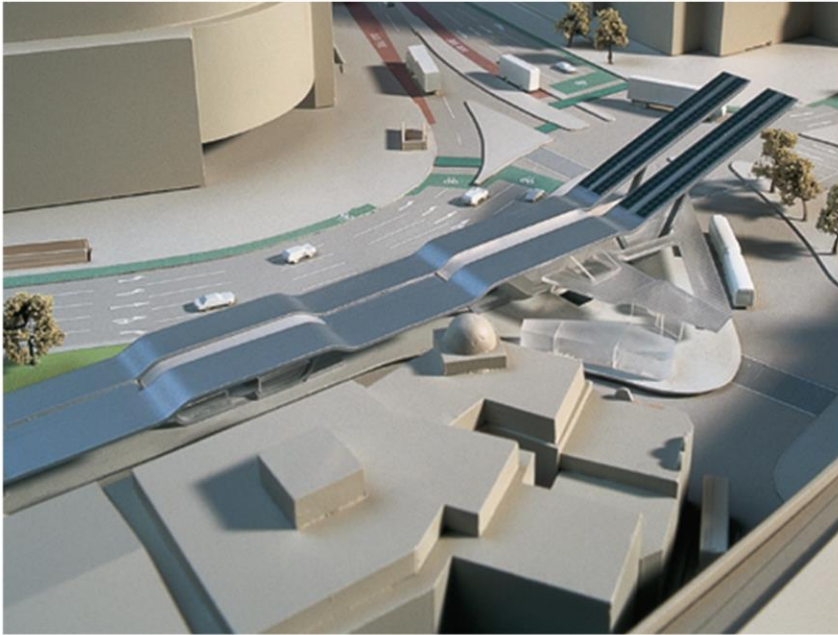

BIPV IS DIFFERENT FROM STANDARD PV

Performance

As much **energy**
as possible

At the **lowest cost**
of investment

Integration

As **functional**
as possible

At the **highest added value**

BIPV IS DIFFERENT FROM STANDARD PV

Performance

No or positive temperature dependence

High efficiency & stability

Efficiencies independent of light intensity & type

Low costs & capex light production

Efficient off-axis light collection

Semi-transparency and grey-scales

Flexible and light-weight

Thin - minimal material usage

Ability for different colors

Integration

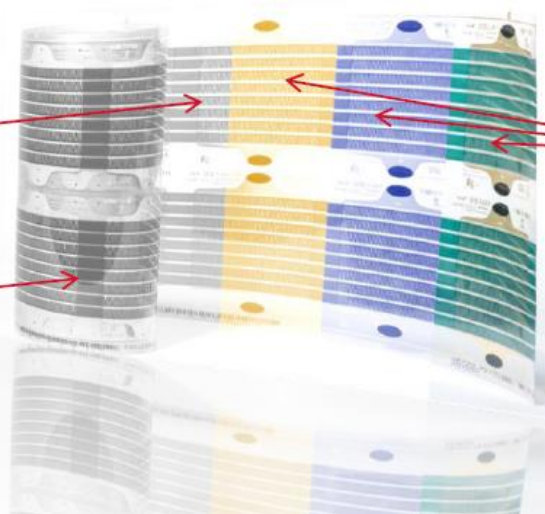

BIPV IS DIFFERENT FROM STANDARD PV



With courtesy from Colt international GmbH

Passive system

- Sun shading
- Design

Active system

- Sun shading
- Design
- Electricity generation

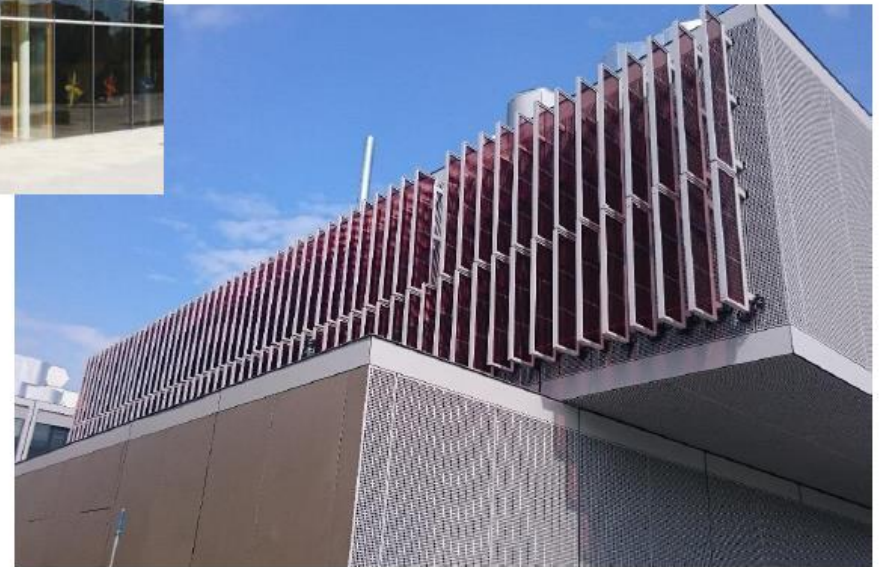

Merck – modular innovation center - Darmstadt

BIPV IS DIFFERENT FROM STANDARD PV

**Colored windows in architecture
(no PV function):**



Diener & Diener / Novartis Campus / Basel, Suisse

**Merck's portfolio of darker
colors (example OPV):**

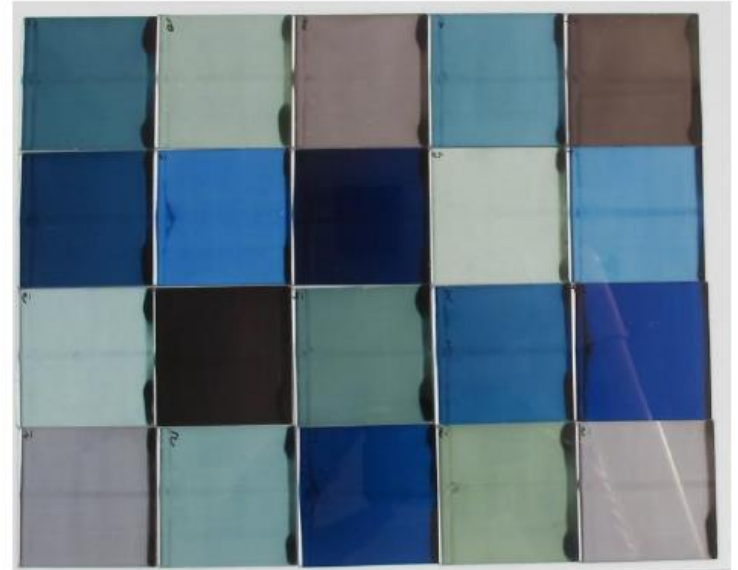

Examples of colors feasible with Merck's OPV solutions

BIPV IS DIFFERENT FROM STANDARD PV

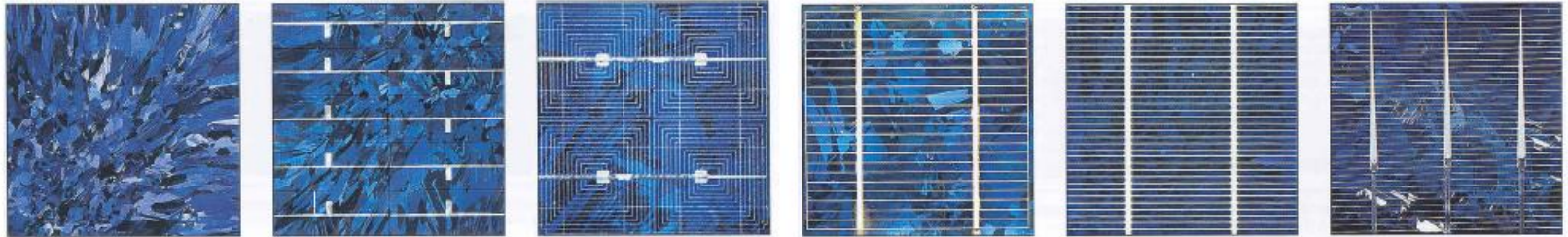

Fig. 3.B.36. different variations of the pattern of metallic grid on multicrystalline cells, © IEA - PVPS Task 7



Fig. 3.B.35. multicrystalline silicon wafers; first the blue antireflective standard colour with the best efficiency, the second is the original wafer without reflective layer, then cells with other colours that have different anti-reflective layers, © Sunways

BIPV IS DIFFERENT FROM STANDARD PV

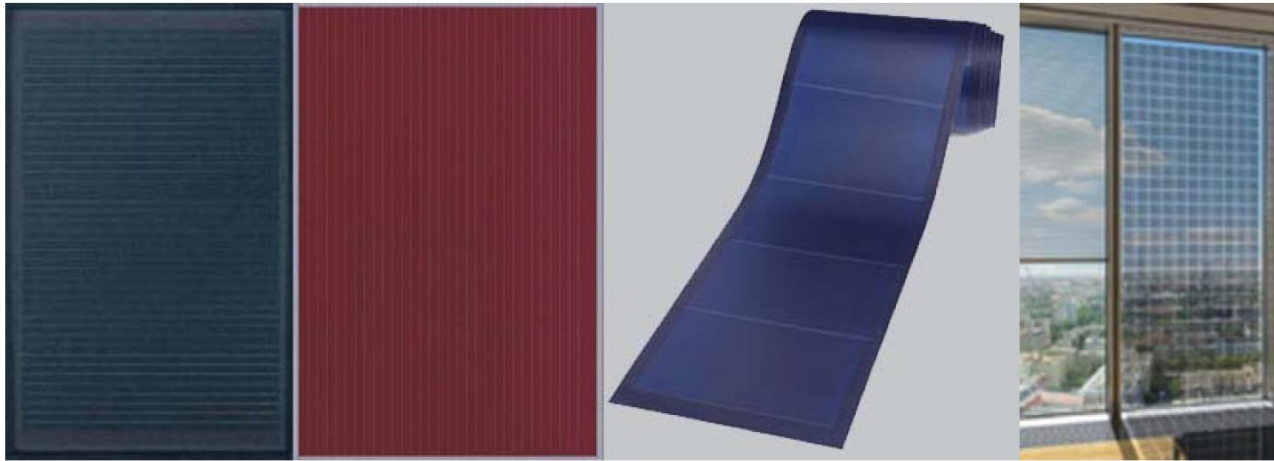
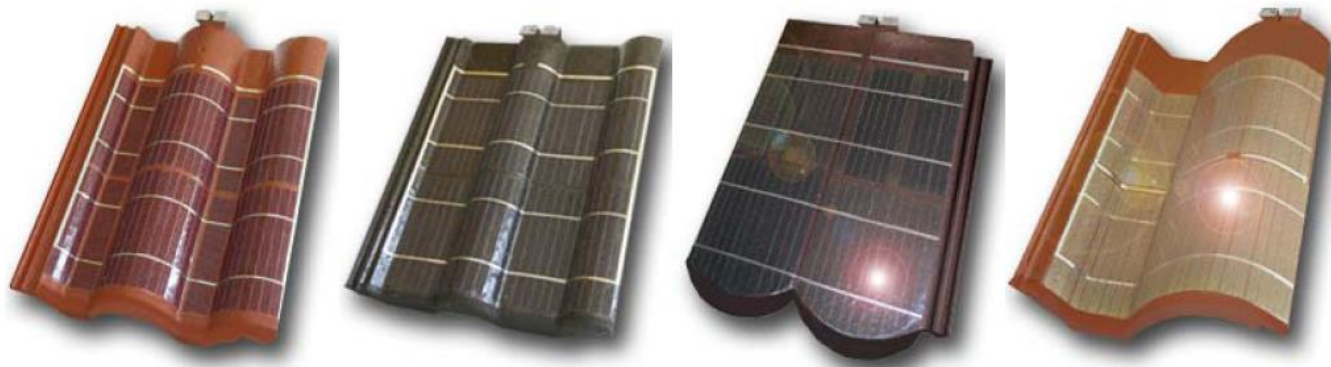

Fig. 3.B.38: black thin film module © Sharp, magenta thin film module © Rixin, solar laminate, © Unisolar, translucent thin film module, © Schüco



Variations of shape of the tile, © IdeaS Solar

BIPV IS DIFFERENT FROM STANDARD PV

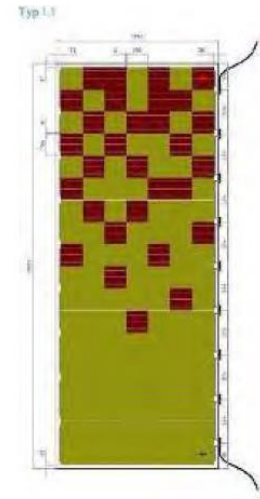

Fig 3.6: home + pavilion for Solar Decathlon, photo of façade and technical drawing of a façade module, ©Prof. Dr. Jan Cremers

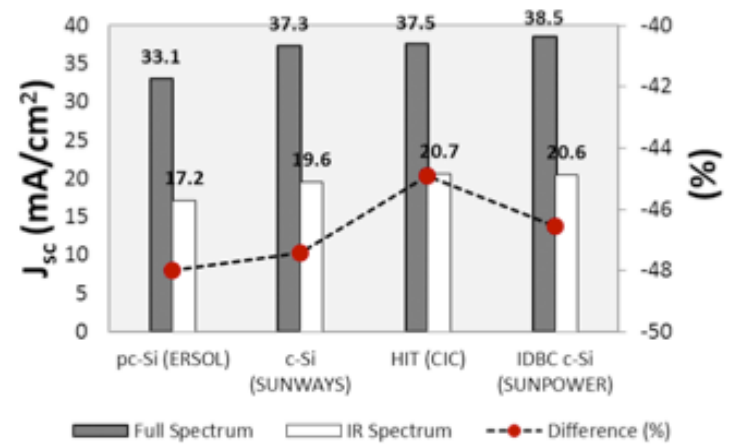
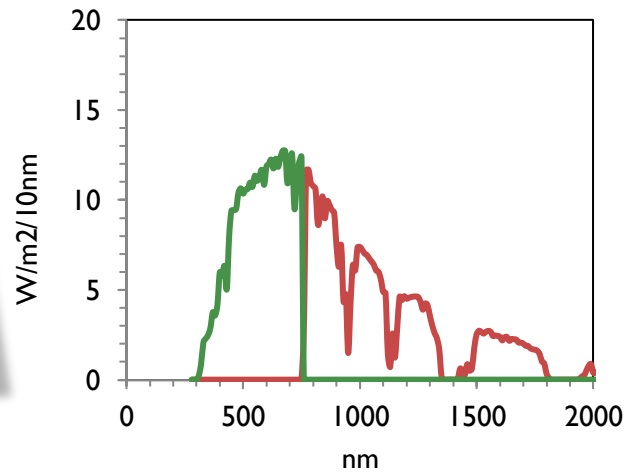
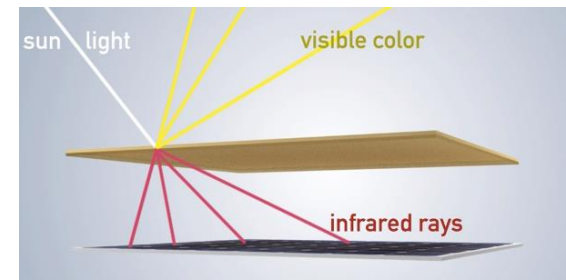
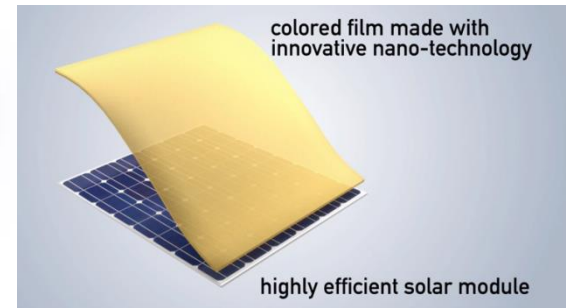

FIGURE 19: A COMPLEX BIPV FACADE IN THE SOLAR DECATHLON "PARA ECO HOUSE" (SOURCE: C. POLO, SUPSI)

BIPV IS DIFFERENT FROM STANDARD PV

SOLAXESS

white solar technology



BIPV IS DIFFERENT FROM STANDARD PV



BIPV IS DIFFERENT FROM STANDARD PV



BIPV IS DIFFERENT FROM STANDARD PV



BIPV IS DIFFERENT FROM STANDARD PV

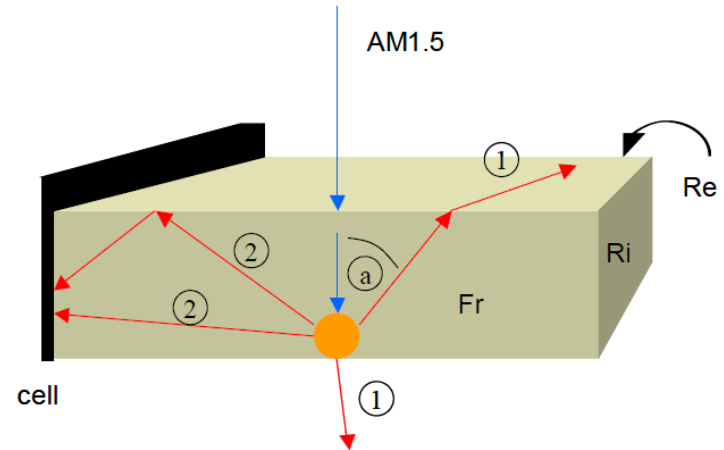

Totally transparent (to the visible light).

Natural sunlight for indoor lighting but only making use of about $\frac{1}{2}$ of the available energy.

Luminescent material absorbs IR radiation and re-emits it with a different 'colour', the photon flux going to the solar cell on the window edge as if in an optical fiber.

BIPV IS DIFFERENT FROM STANDARD PV



Onyx Solar Photovoltaics Transparent Glass installed into San Anton Market, Madrid (Spain)

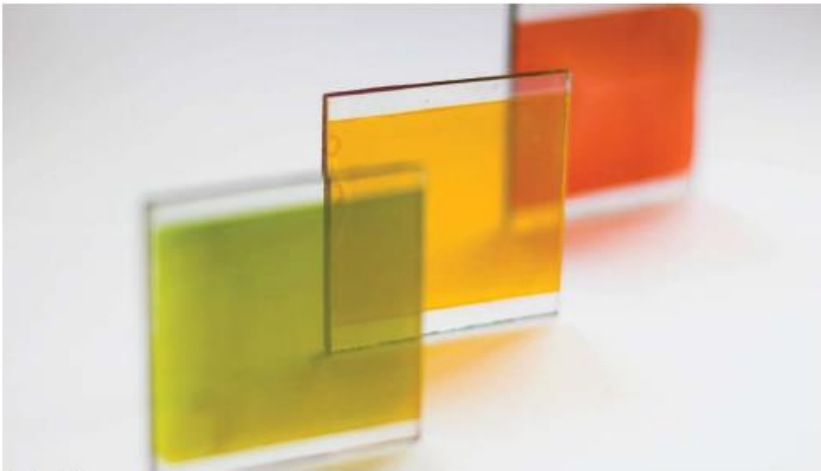

Oxford PV

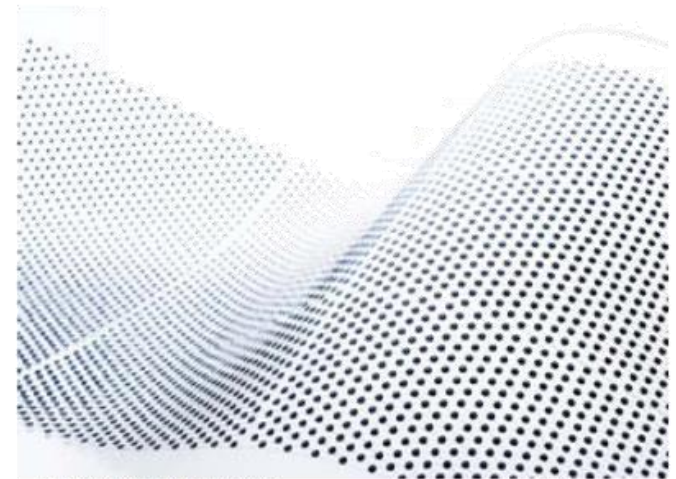

Sphelar® by Sphelar Power
Based on crystalline silicon balls, © module

BIPV IS DIFFERENT FROM STANDARD PV



First prototype of the new angle selective façade (without PV functionality).

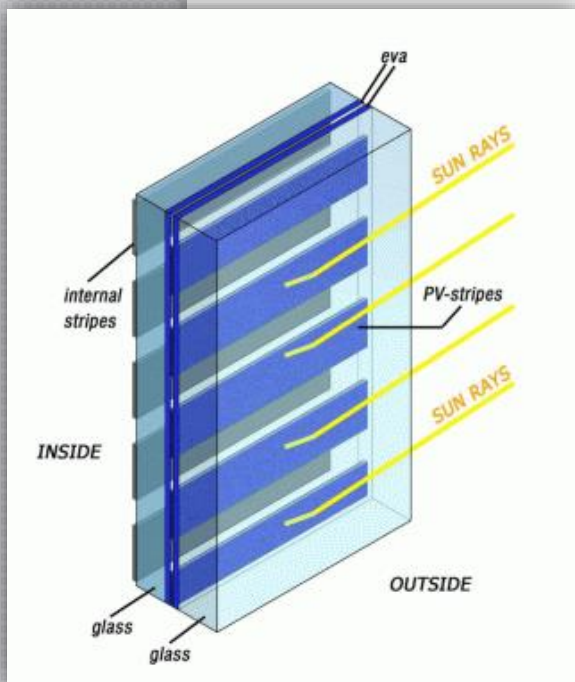

The alignment of the two sets of strips leads to very sensitive obstruction to light as function of the incidence angle.

BIPV IS DIFFERENT FROM STANDARD PV

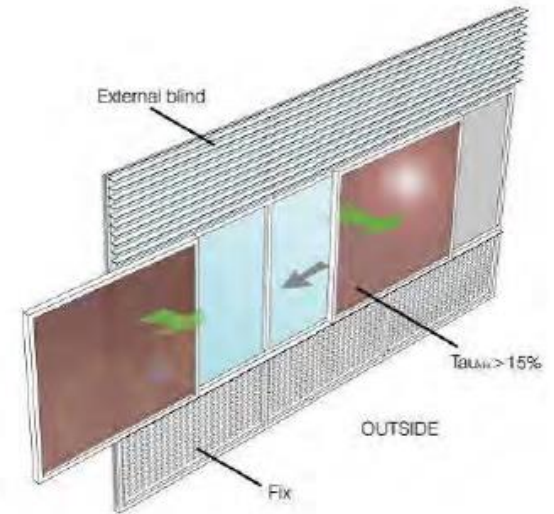
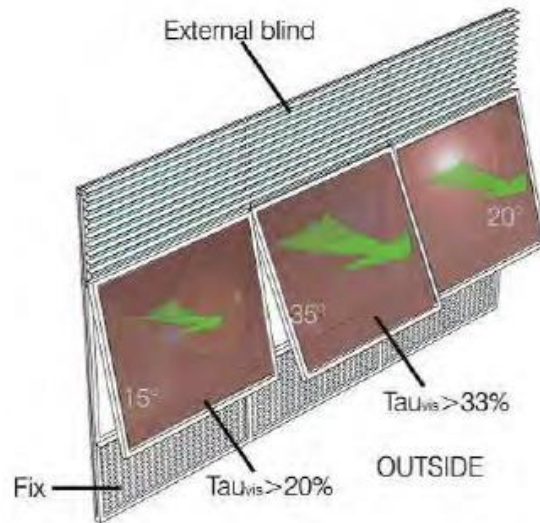
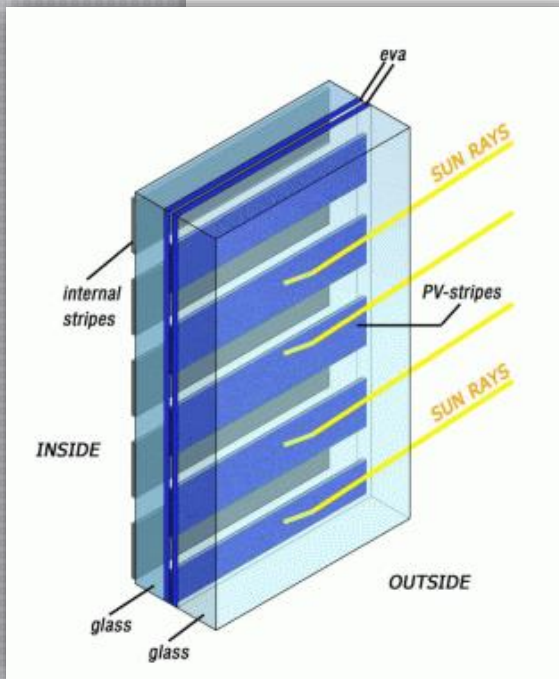
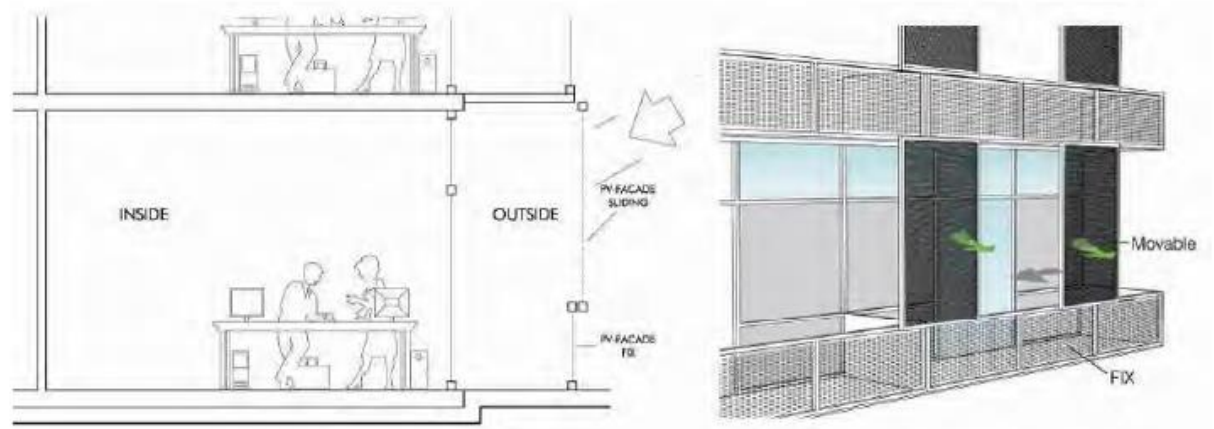

The pictures present an idea of the integration of the new façade as an external shading device.

BIPV IS DIFFERENT FROM STANDARD PV

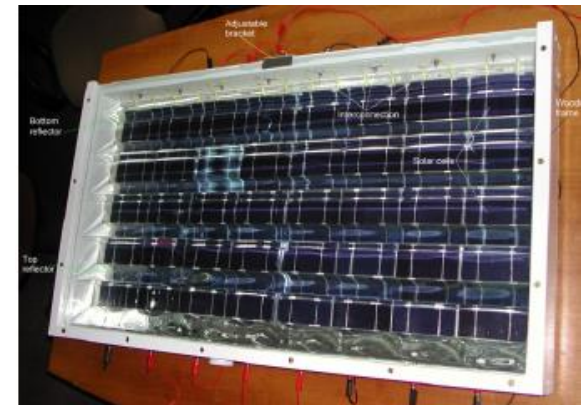
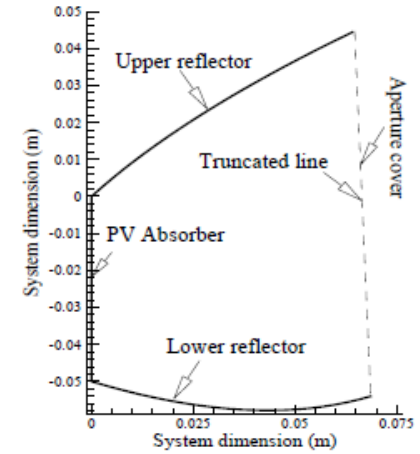
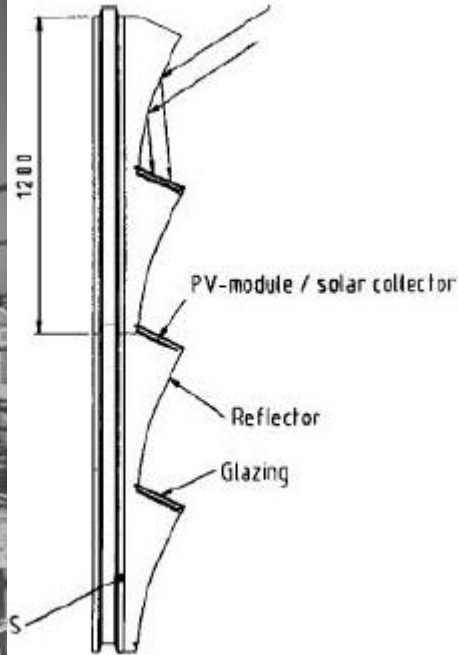

BIPV IS DIFFERENT FROM STANDARD PV

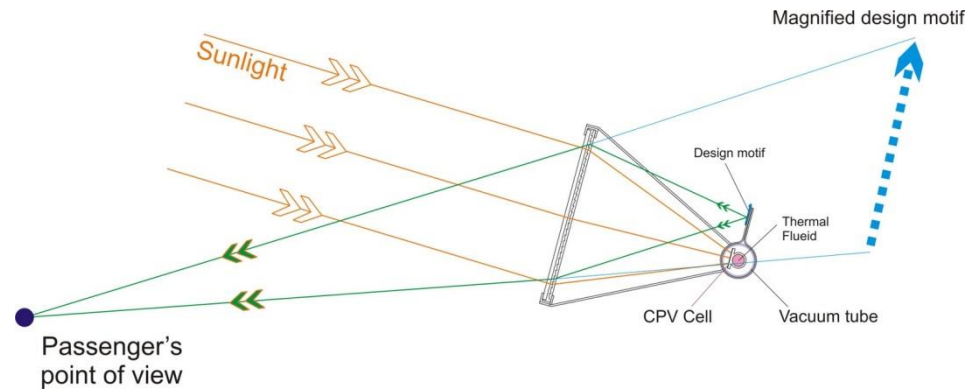
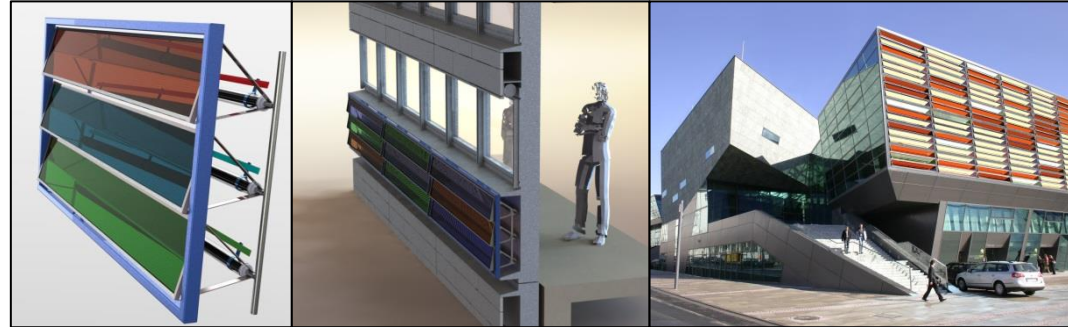
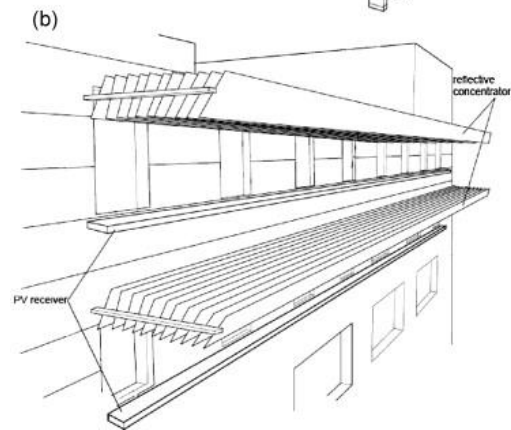
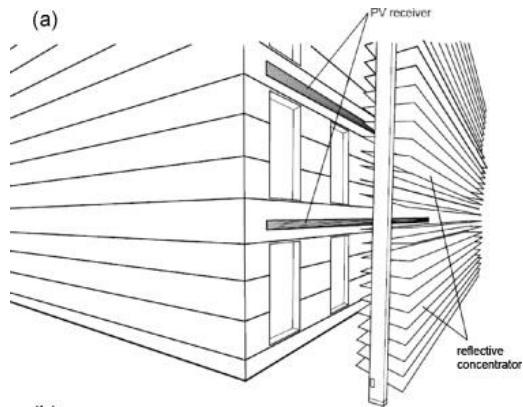

BIPV IS DIFFERENT FROM STANDARD PV

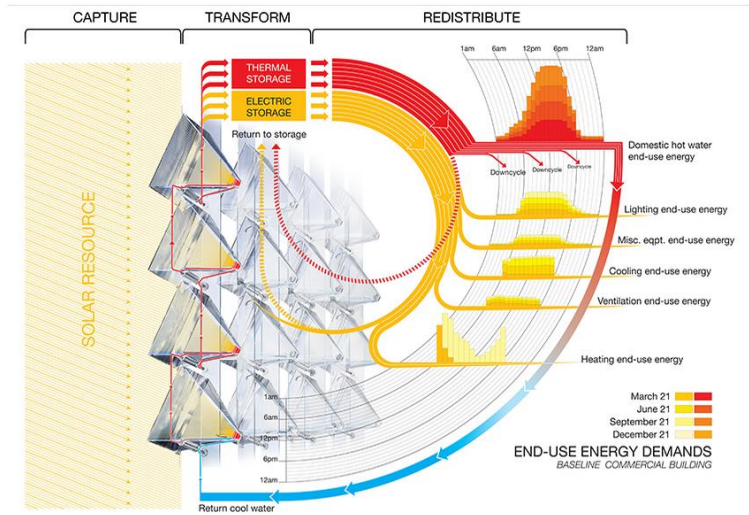

Kinetic solar facade

Moving concentrating glass prisms for beam solar irradiation

- ❑ Diffuse radiation gets through for indoor lighting
- ❑ Heat is collected and may be used for heating/cooling of the building

BIPV IS DIFFERENT FROM STANDARD PV

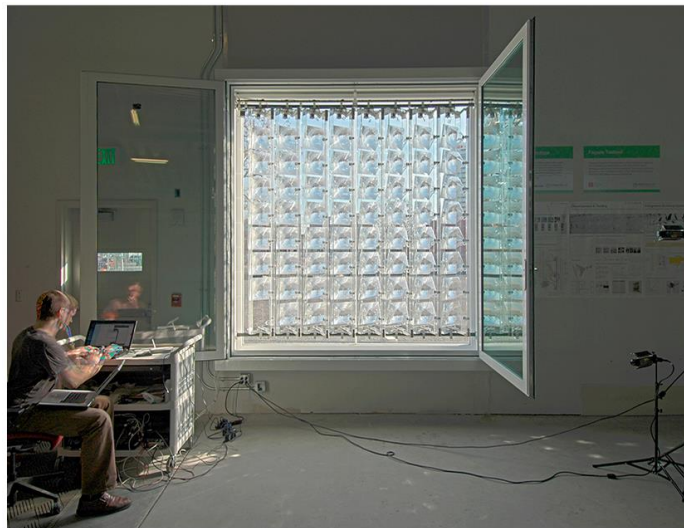
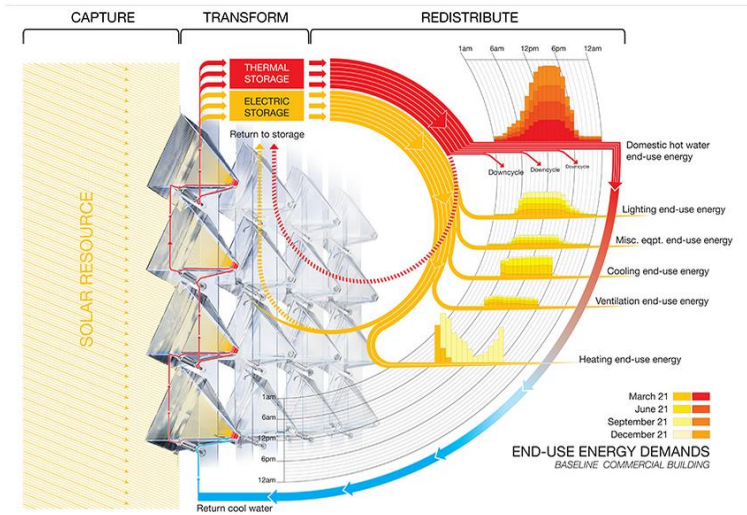

THE COST OF BIPV

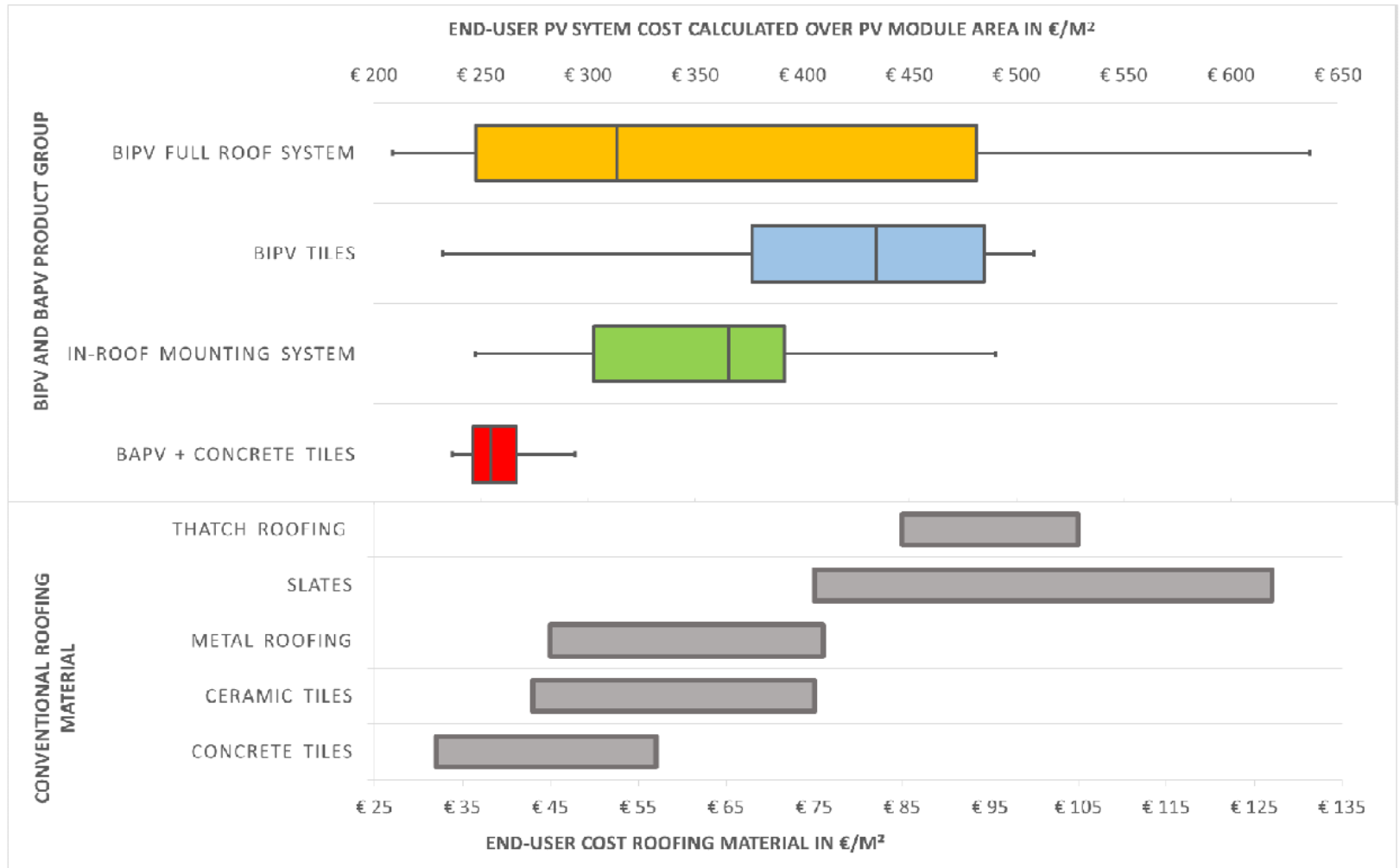

THE COST OF BIPV

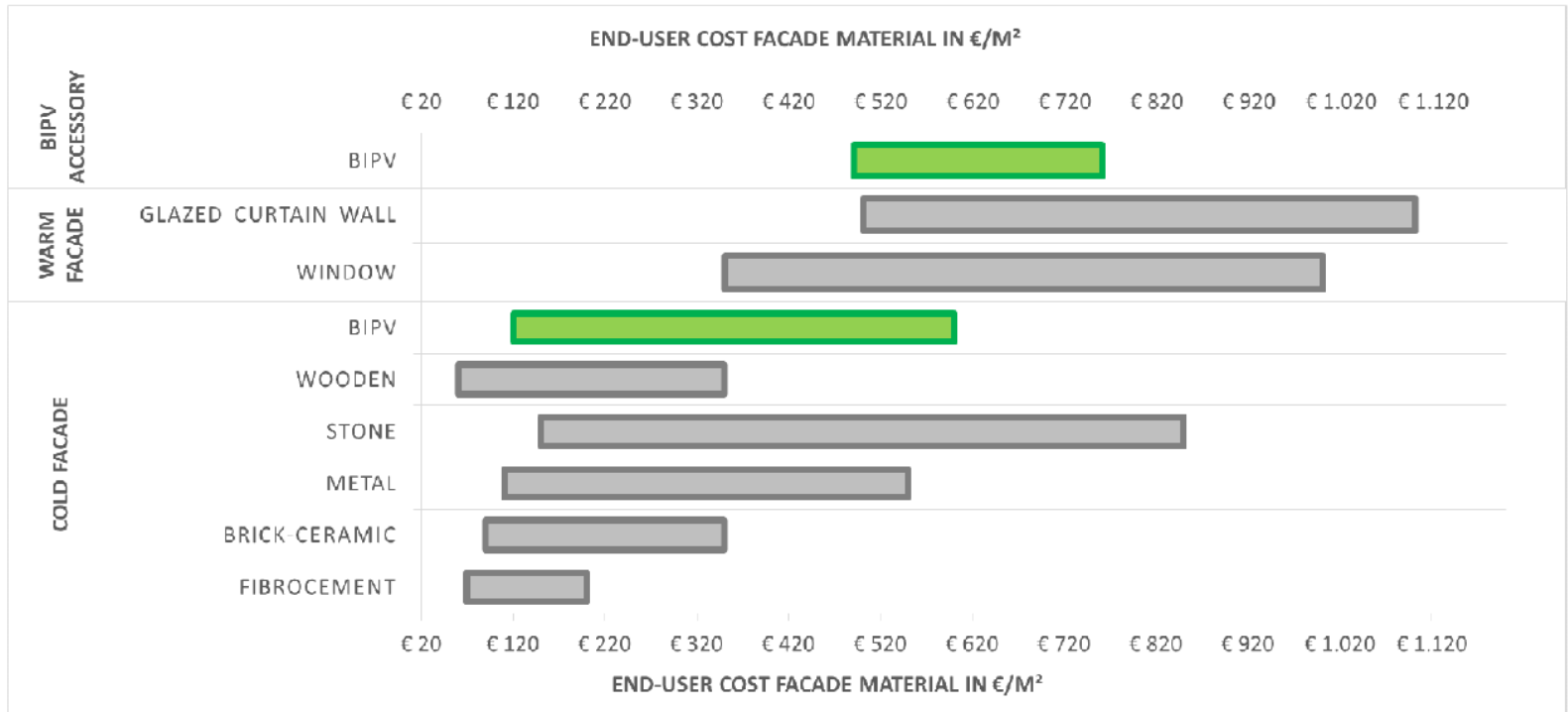

THE COST OF BIPV

Comments

- ❑ Roof BIPV market more developed than facades
- ❑ Average end-user price is about 300 €/m², in spite of large range of prices
- ❑ Assuming 15% efficiency (150W/m²) one gets 2€/W so there is a +200% premium for BIPV [compare with 0.60 €/W for factory gate module]
- ❑ But we're avoiding using other roof/facade materials with similar costs (but less 'function') so one can argue that **BIPV is free.**

BIPV in public spaces

- Increase locally produced renewable **electricity**
- Bring PV closer to the **people**
- Promote **sustainability** (usually more visible than when in/on buildings)
- Examples:
 - Urban street equipment
 - Shelters, barriers, shading structures
 - Urban art

BIPV in public spaces

Main design issues

- Solar **resource** (shadings more likely)
- Visual **appearance** (key issue)
- **Vandalism** and theft
- Easy **maintenance**
- **Cost**

BIPV in public spaces



BIPV in public spaces





BIPV in public spaces



BIPV in public spaces



BIPV in public spaces

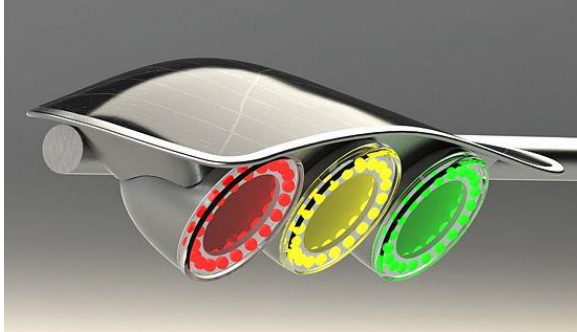

BIPV in public spaces

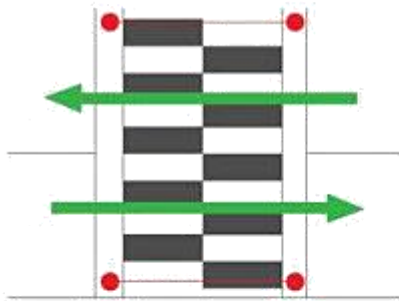

A driver drive on

A pedestrian stop at a crosswalk

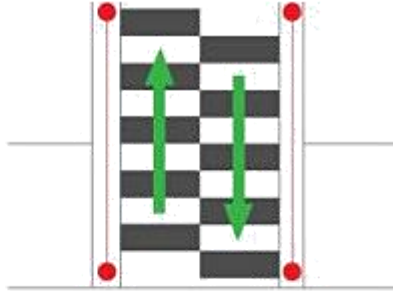

A driver stop a car at a crosswalk

A pedestrian cross the street at a crosswalk



BIPV in public spaces



BIPV in public spaces



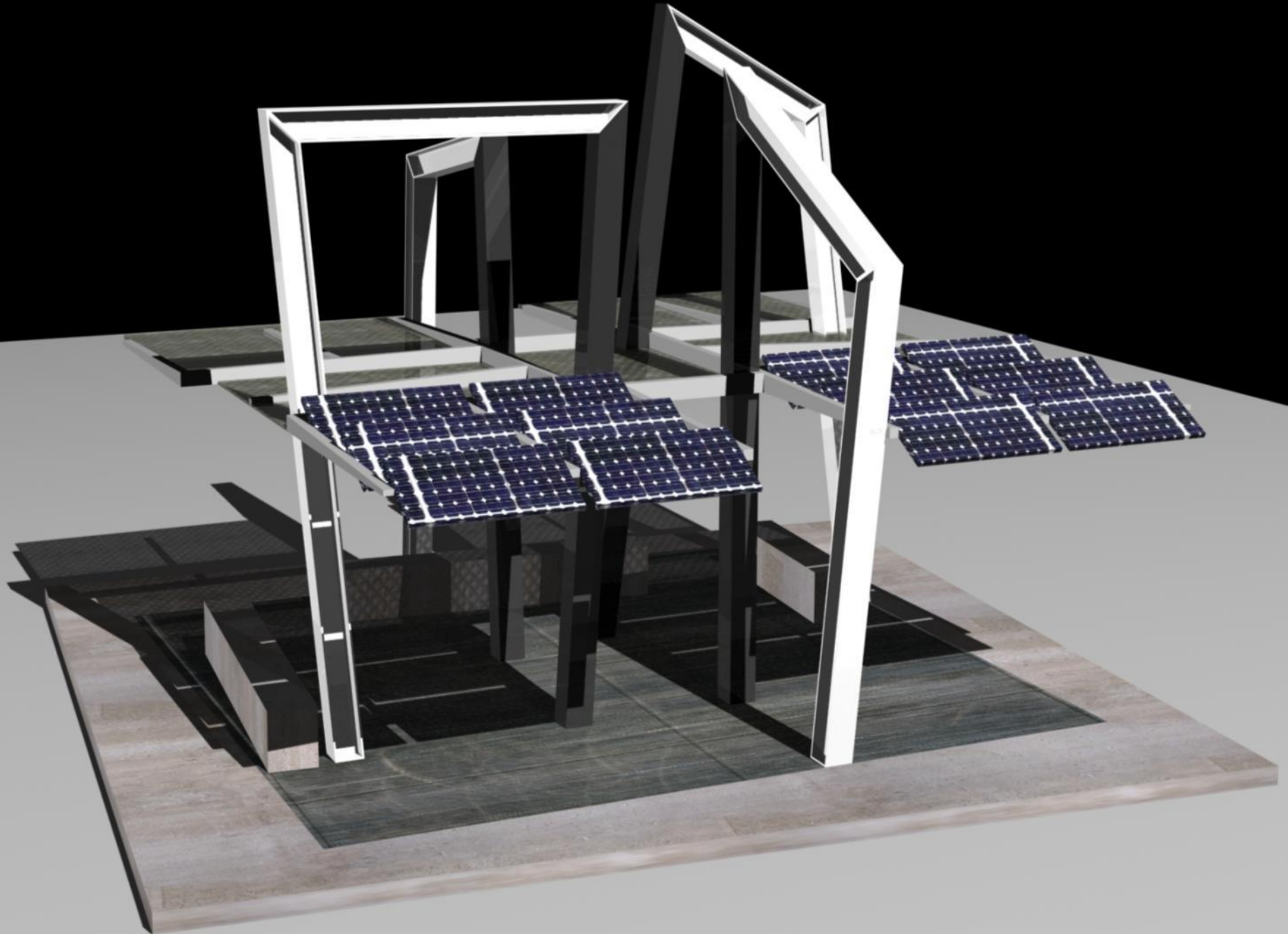



SONIC BLOOM @SEATTLE FESTIVAL 2015

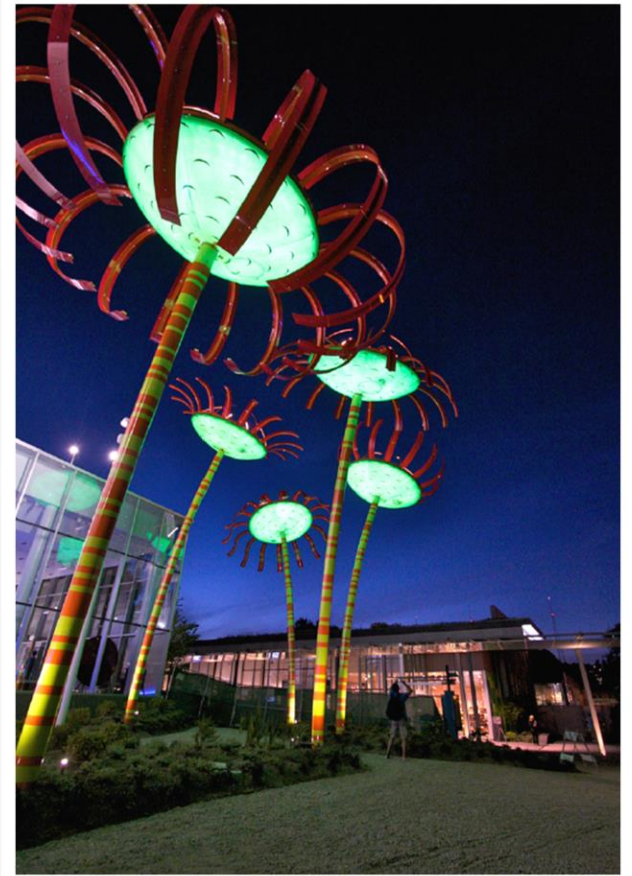

sensors located in each flower are triggered by people's movement, setting off a chorus of interactive harmonic tones

mounted on the top of each painted flower head are 46 locally made photo voltaic cells that collect the energy from the sun and feed it back into the electrical grid. this sustainable feature completely offsets the energy-efficient LED lighting and speaker electrical consumption for the project.

Further reading

BIPV PRODUCT OVERVIEW FOR SOLAR FAÇADES AND ROOFS

BIPV STATUS REPORT 2015, SUPSI - SEAC

Francesco Frontini, Pierluigi Bonomo, Anatoli Chatzipanagi
Swiss BIPV Competence Centre, SUPSI

Guus Verberne, Menno van den Donker, Kostas Sinapis, Wiep Folkerts
Solar Energy Application Centre (SEAC)

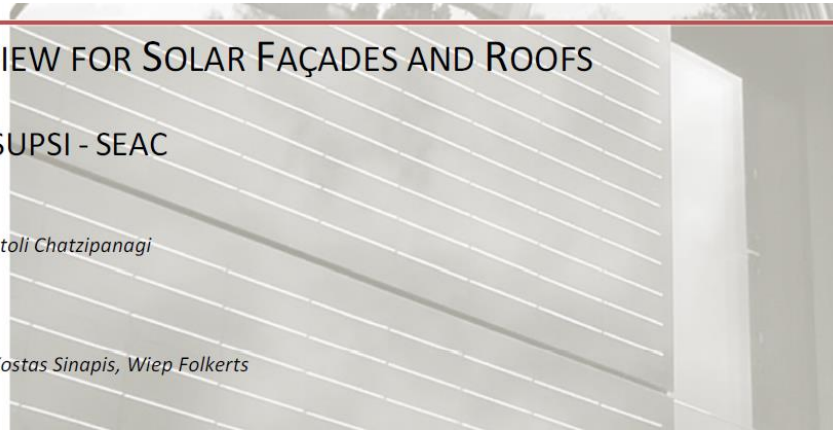

T.41.A.2 | Task 41 - Solar energy & Architecture  International Energy Agency - Solar Heating and Cooling Programme

SOLAR ENERGY SYSTEMS IN ARCHITECTURE



integration criteria and guidelines

DESIGNING PHOTOVOLTAIC SYSTEMS FOR ARCHITECTURAL INTEGRATION



criteria and guidelines for product and system developers₆₇